

Process & Production Engineering **Directory**

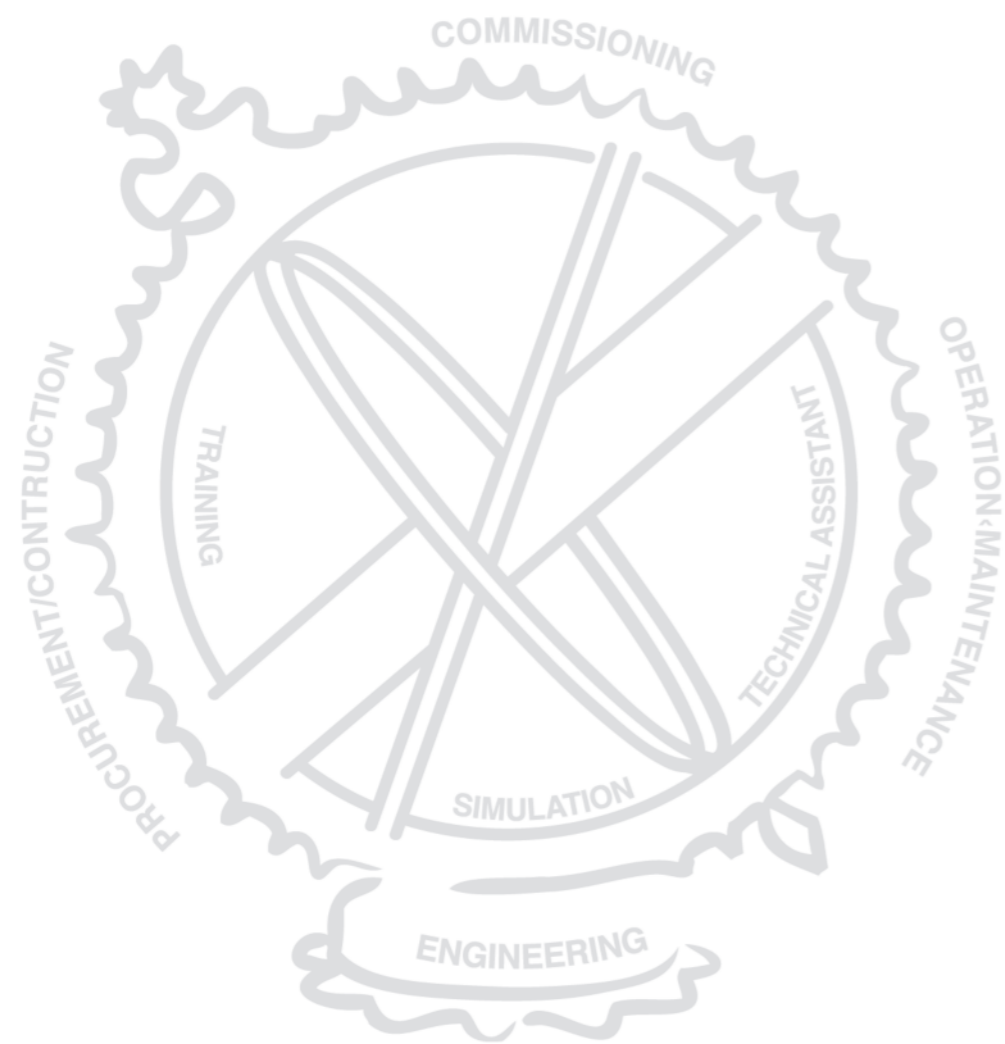

INTEGRATED **S**ERVICE **S**OLUTIONS



| | | |
|------------------|--|----|
| CHAPTER 1 | INTRODUCTION | 4 |
| CHAPTER 2 | PROCESS & PRODUCTION ENGINEERING SERVICES | 5 |
| | 2.1 Operating manuals and SOP/POG | 5 |
| | 2.2 Commissioning & start-up procedures | 8 |
| | 2.3 Simulation services | 10 |
| | 2.4 Process studies | 13 |



CHAPTER

1

Introduction

ISS International offers completed and integrated process and production engineering services mainly for Oil & Gas and Power Generation industry.

ISS International supplies services and develops innovative solutions (Dynamic Simulation) to improve Plant Design and Profitability.

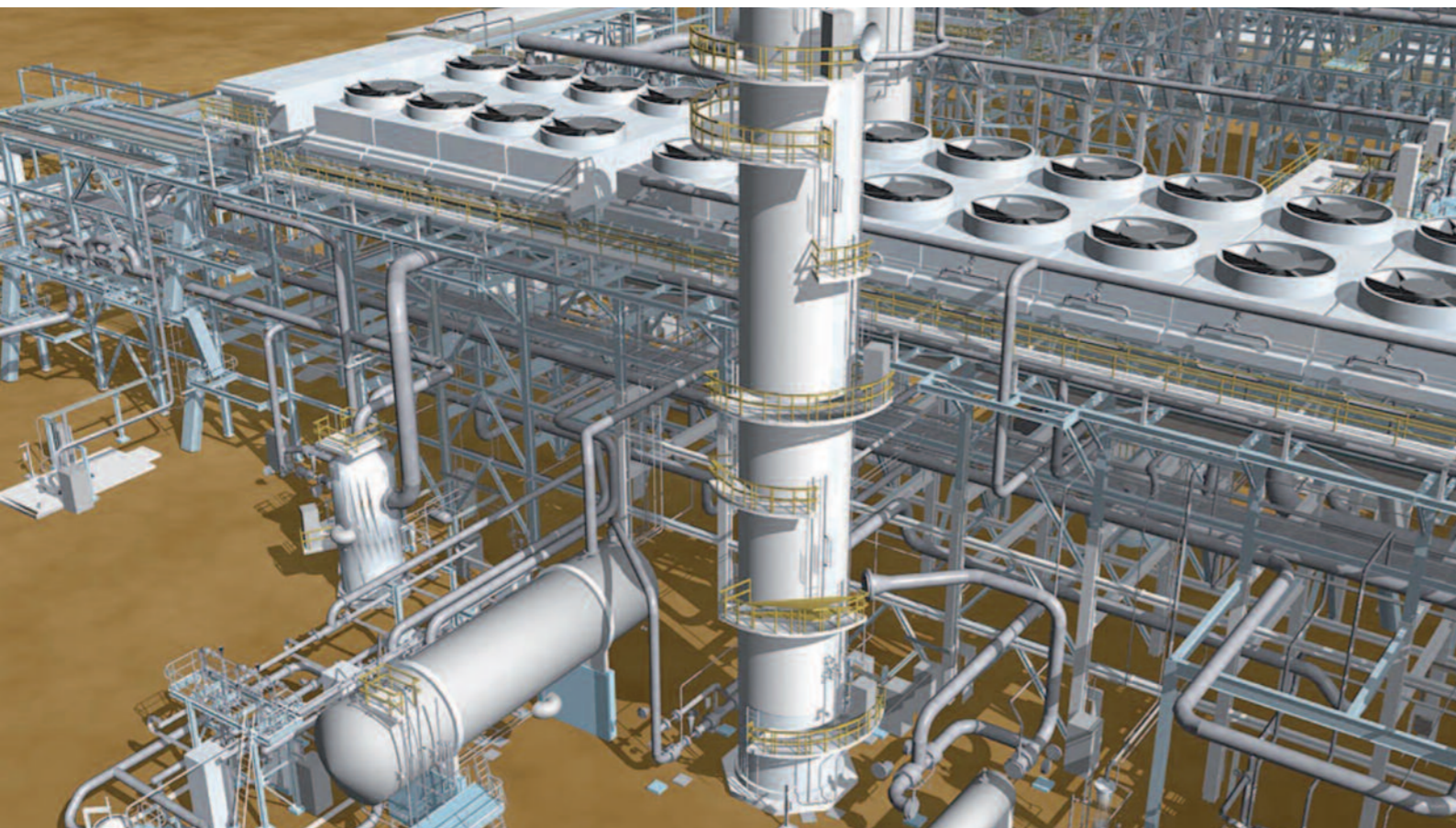

CHAPTER

2

Process & Production Engineering Services

Thanks also to our extended experiences in the field activities, **ISS International** always bears in mind that engineering is strictly connected to construction, commissioning and operation. So, **ISS International** may develop:

- Operating Manuals
- Pre-Commissioning Procedures
- Commissioning & Start-Up Procedures
- SOP / POG (step by step)
- Simulation for Engineering Support / Purpose
- Feasibility and De-bottlenecking Study
- Basic Design

2.1 OPERATING MANUALS AND SOP/POG

ISS International develops manuals and procedures providing a product/service as follows:

- Detailed Reference for Operating Personnel
- Easily Accessible
- Full Comprehensive Information
- Easily Update
- Suitable for New Communication Technology

Normally, **ISS International** develops Operating Manuals and relevant Procedures on the basis of the following main points:

- Plant General Description
- Plant Detailed Procedures
 - Units Detailed Procedures
 - Main Equipment Procedures (Specific Tags)

- Common Equipment Procedures
- Auxiliary Procedures
- HSE Impact

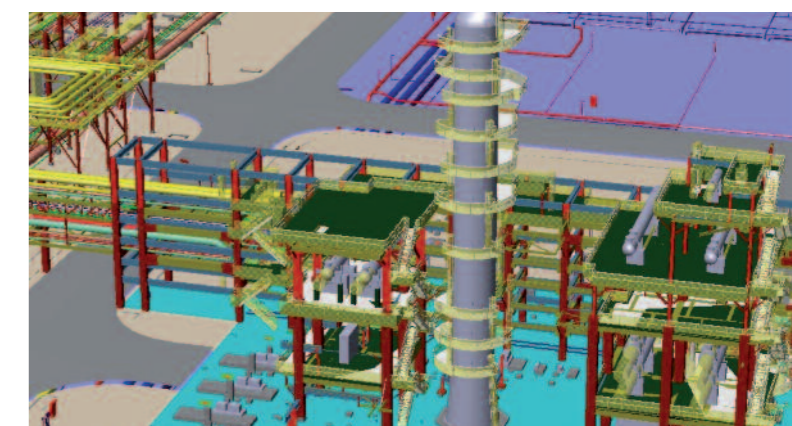



In particular, a general index for Plant Operating Manual is shown below:

1. Introduction

- 1.1 General

2. Basis of design

- 2.1 Plant Duty
- 2.2 Environmental conditions
- 2.3 Feedstock and Product Specifications
- 2.4 Battery Limit Conditions
- 2.5 Specifications and Consumptions of Utilities, Chemicals and Catalysts

3. Process description

- 3.1 Process Theory
- 3.2 Process Flow Description
- 3.3 Process Control Variables
- 3.3 Process Chemistry

4. Safety information

- 4.1 Unit Alarms Set Points
- 4.2 Unit Trips (ESD and PSD) Set Points
- 4.3 Depressurization
- 4.4 List of Relief Valves
- 4.5 Fire Protection
- 4.6 List of PPE and Specific Safety Equipment

5. Preparation for initial startup

- 5.1 General
- 5.2 Plant Inspections
- 5.3 Cleaning of Piping and Equipment
- 5.4 Specific pre-Start-up Operations

6. Start-up procedures

7. Normal operation

8. Shutdown procedures

- 8.1 Planned Shut-Down
- 8.2 Emergency Shut-Down

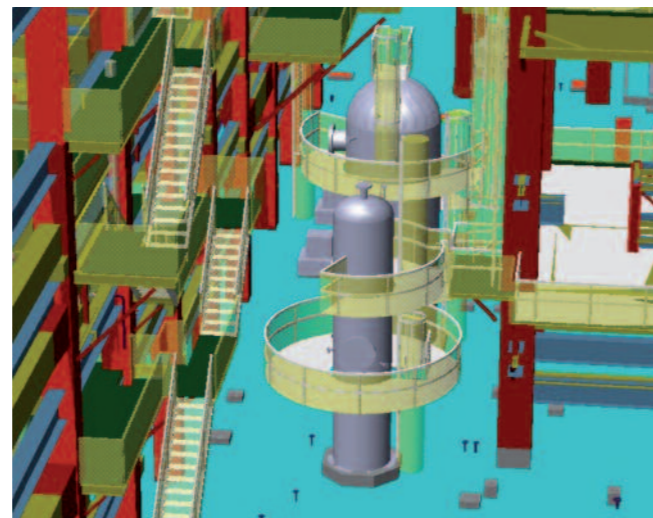

The innovative **ISS International** approach is to have Manuals developing with a multiply set of small and accessible books.

This approach generates an innovative working book which is also an efficient training instrument.

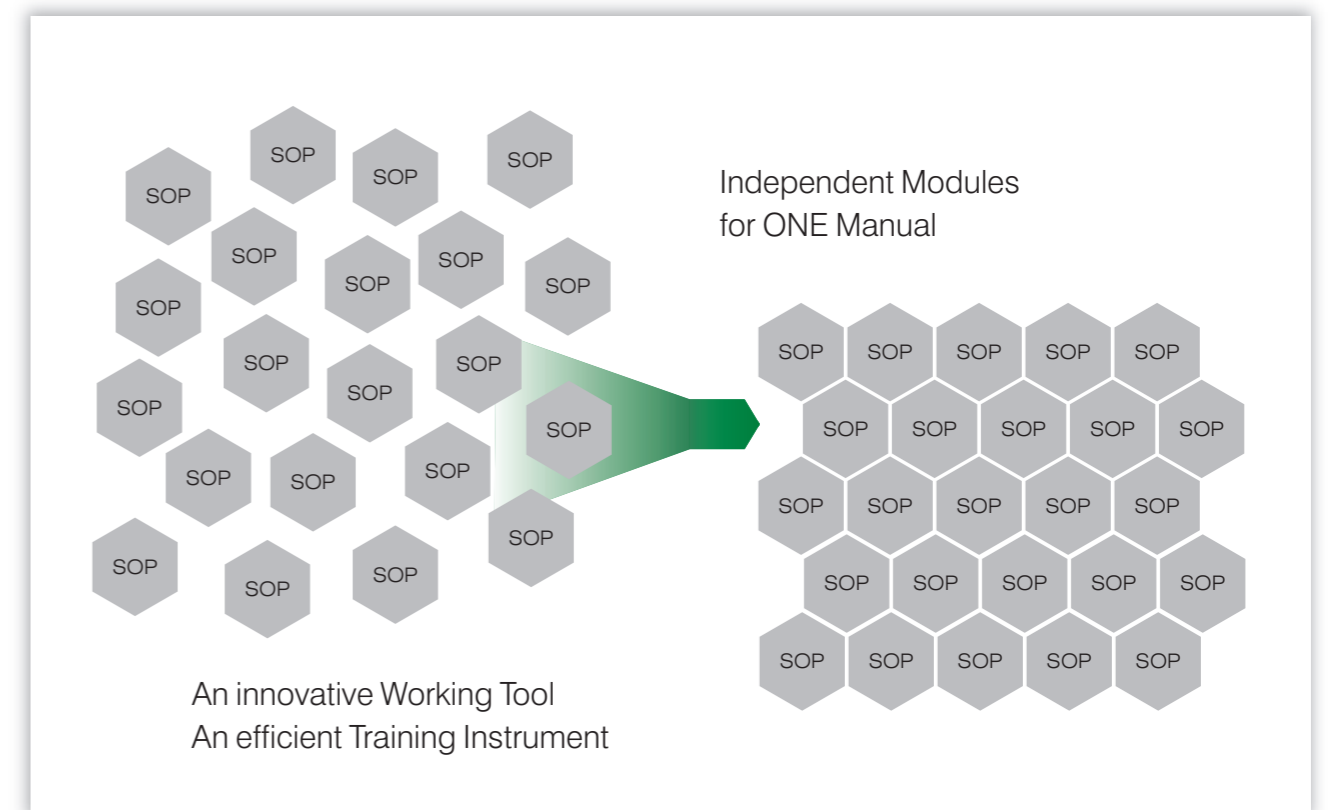



2.2 COMMISSIONING & START-UP PROCEDURES

ISS International is well experienced in pre-Commissioning and Commissioning activities and can provide the in-depth experience, guidance and qualified personnel necessary to deliver a Unit safely prepared and ready to achieve a successful start-up.

The senior technicians and the engineers who make up the staff have been all chosen on the base of professionalism, versatility and ability to adapt to the

differ ent environment and industrial culture of Customer, covering both Home-Office and Site phases, providing specific consultancy and technical assistance services as well as implementation of fully integrated projects.

ISS International commissioning management path is as follows:

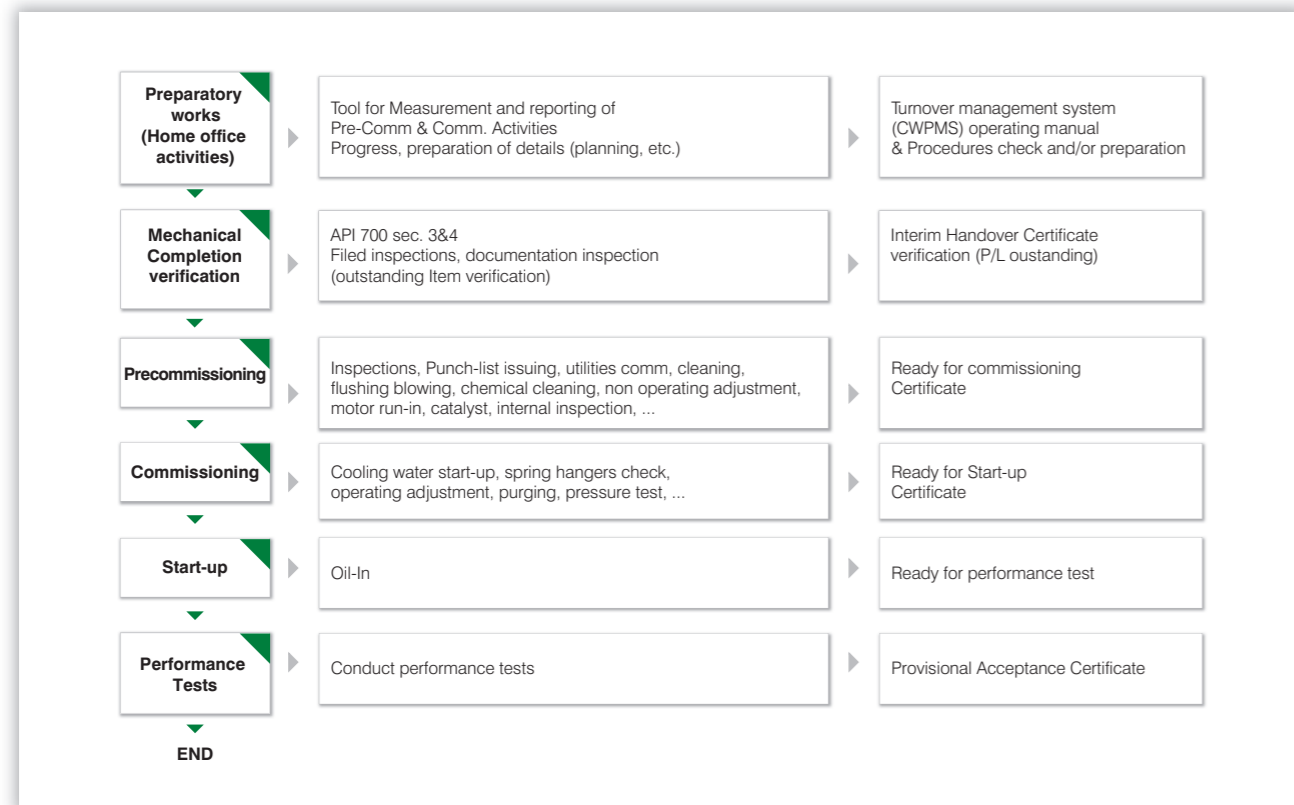

ISS International is developer and owner of a software dedicated to manage every commissioning activity, **TMSCOM®** (Turnover Management System).

The purpose of **TMSCOM®** is to provide the appropriate tool to follow the Client & Contractor policies, procedures and quality (QA/QC) checks, in order to administrate all the documentation and to control the Turnover.

Main Password

Main Menu

Punch List

Discipline Tag Main Menu

TAG Mng System

Plant System Mng



ISS International develops Pre-commissioning and Commissioning Manuals as a collection of pre-commissioning procedures; these procedures are operating instructions, step by step type, for the activities to be carried out during the performing of pre-commissioning and commissioning activities.

The main list of the procedures to be carried out is:

- Mechanical Preparation
- Chemical Cleaning Instructions
- Physical Cleaning Instructions
- Mechanical Restoration
- Machinery Run in
- Tightness test
- Electrical testing/functional tests/energizing
- Instruments calibration and functional test
- Loading of chemicals
- Loading of catalyst
- Heaters drying
- Chemicals boil out of steam generation facilities
- Verification of Mechanical Completion
- Performance Test

2.3 SIMULATION SERVICES

ISS International provide engineering services that involve our team to use Simulation Tools, helping our Client during the design phase.

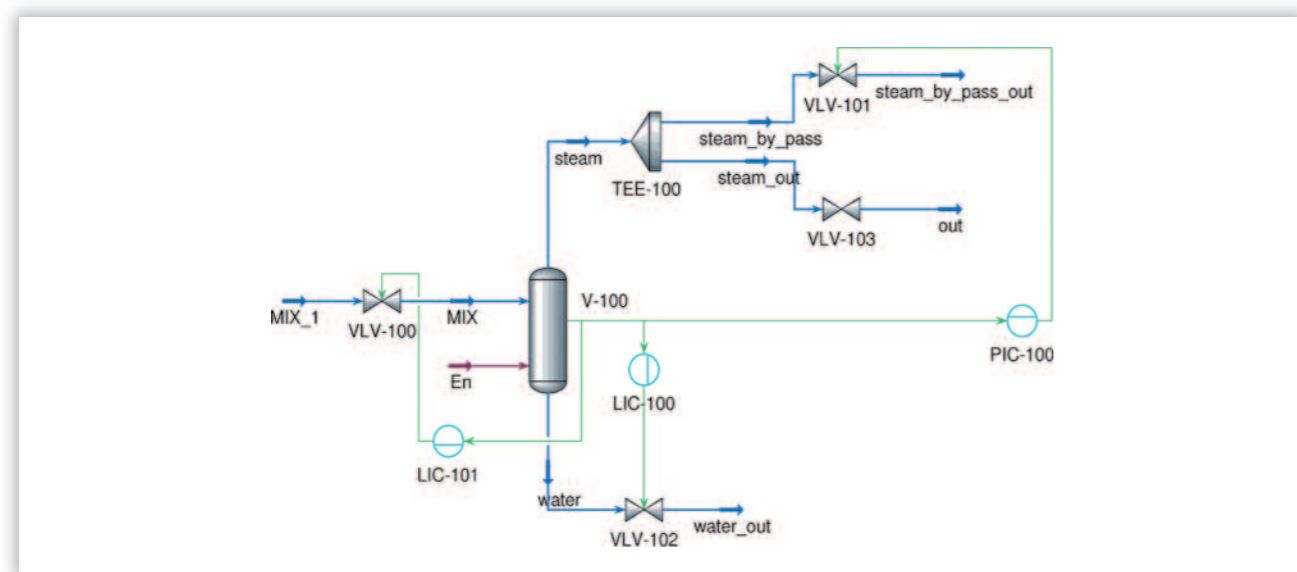

ISS International engineering support covers the following main application fields:

Steady State Simulation:

- Heat & Material Balance Calculation
- Compressors Curves Calculation
- Equipment Data sheets Calculation
- Plant/Systems Data Reconciliation

Dynamic State Simulation:

- Validate/Verify Design Parameters
- Verify the Operability of the Plant with the Actual Control System
- Provide a First Tentative Tuning of Controllers
- Check the Settings of the Trip System
- Verify the Operating Procedures
- Feasibility Studies (Revamping troubleshooting and De-bottlenecking)

Can you rapidly determine the most profitable, controllable, and reliable design?

By taking advantage of integrated steady-state /dynamic modelling, the tradeoffs between optimal steady-state design and operability may be considered to design processes that minimise capital investment and are robust, safe, and easy to operate.

Do you suffer from lengthy start-ups, difficulty in meeting product specifications and unplanned downtime?

Process industry audits estimate that only 20% of control loops reduce process variability while 80% actually increase it! **ISS International** service enables our Clients to understand the source of bottlenecks, process upsets, and quality problems, thus helping identify opportunities to eliminate them. It is possible, also, to evaluate control strategies, tuning parameters, and model start-ups and shutdowns to improve plant performance.





ISS International using the **Case Study Tool**, automates the collection and presentation of sensitivity analysis results. It enables engineers to identify key variables for optimisation, determine process sensitivities

and understand relationships between operations. Results may be presented in 2D or 3D plots and tabular format. The case study is an excellent tool for process exploration prior to detailed optimisation.

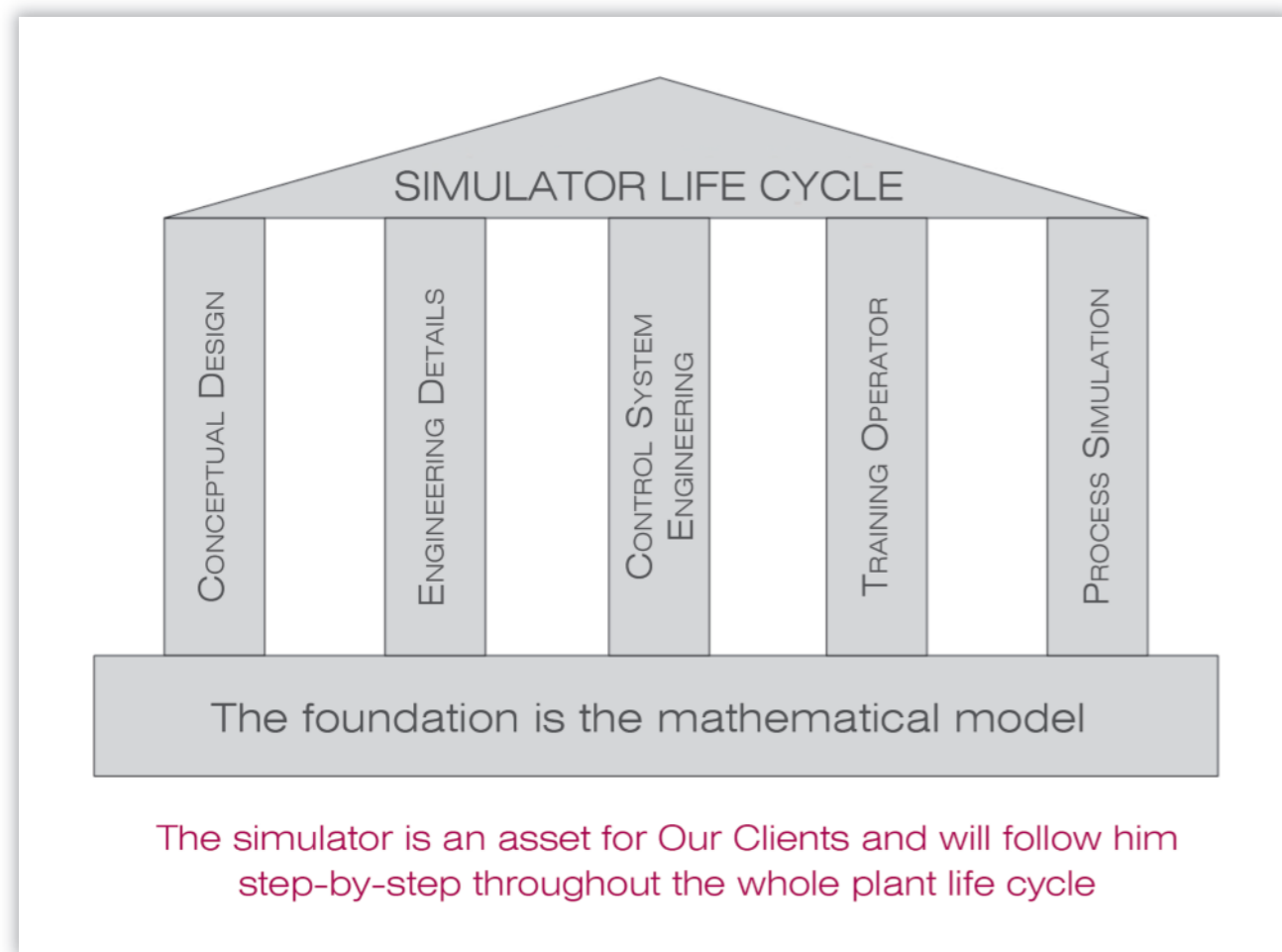

2.4 PROCESS STUDIES

ISS International may provide a full range of process services to its Client as follows:

Basis of Design

- Process Design Criteria and Standards

Process Description

- Process Design Features
- Process Description
- Process Control Philosophy

Process Flow Diagrams that include:

- All process equipment with relevant item tag
- Main process control loops
- Temperature and pressure for main process streams
- Duties for thermal equipment
- Streams identification tag for detailed material balance
- ...

Material Selection Diagram

- Process Flow Diagram showing material selected, corrosion allowance for process piping and equipment

Material Balance

- Overall material balance
- Detailed material balance for the design feedstock cases, if any

Utilities Consumptions

- Summary of utilities consumptions
- Utilities requirements for plant start-up and safe shut-down, including peak consumptions
- Electrical load summary

Effluent Summary

- Solids release
- Liquid effluents
- Gaseous effluents
- Recommended method of disposal

Relief Summary

- Summary of rates discharges to relief valves for all the potential emergencies
- Gas Cabinet Pressure Relief Valves Calculation Note

Management of Technological Risk

- ARA
- HAZID
- HAZOP
- ...

Piping & Instrument Diagrams that shows:

- All itemized equipment
- All lines with indication of diameter, piping class and general identification of insulation and tracing (if required) and relevant valves, check valves and safety valves
- All the control valves and instrument with detailed control loops
- Process requirements concerning elevation of equipment, slope of piping, maximum or minimum length of lines (where required)
- All tie-ins points with an identification number, if any
- For utilities, preliminary piping and instrument diagrams showing basic arrangement of utility networks
- ...



Equipment List

- It indicates identification tag and service for each item with a description of main characteristics

Equipment Specifications

Individual data sheets for relevant equipment include the following information:

HEAT EXCHANGERS

- Type (shell and tube, plate fin, plate, air cooler) for shell and tube exchangers type will be specified according to TEMA nomenclature
- Operating data
- Design conditions (pressure and temperature)
- Construction material (general identification)
- Corrosion allowance
- Nozzles size and rating
- Insulation
- Heating or cooling curves
- Any necessary design notes

COMPRESSORS

- Number of process stages
- Suction and discharge pressure of each stage
- Suction temperature of each stage
- Estimate discharge temperature of each stage
- Capacity of each stage
- Design conditions (pressure and temperature)
- Definition of capacity control
- General definition of accessories
- General definition of instrumentation
- Type of driver

- Any necessary design notes

■ ...

Instrumentation

INSTRUMENT LIST

Instrument process data sheets for:

- Control valves
- Flow elements
- Safety valves
- Analyzers
- Alarm and trip system basic definition
- Cause & effect diagram
- Advanced control functions description
- ...

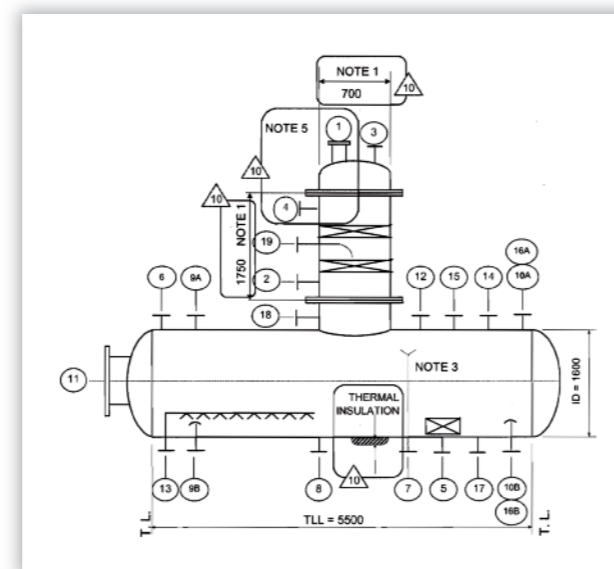

To see our
Partner network,
visit our web site:

www.iss-international.it at the **Reference Clients** section

ISS International/Main/Final Clients



WE GLOBALIZE
JUST FOR YOUR BUSINESS



ISS International SpA

Headquarters

Via Magna Grecia, 117 - 00183 Rome, Italy

Phone: +39 06 4522821

Fax: +39 06 45200351

www.iss-international.it



ISS International SpA - Training Center

Via Magna Grecia, 117 - 00183 Rome, Italy

ISS International is certified:

ISO 9001 EA35

ISO 9001 EA37

ISO 14001

OHSAS 18001



The present document is property of ISS International SpA and shall not be totally or partially, directly or indirectly, transferred, reproduced, copied, disclosed or used, without the authorization of ISS International SpA.